

END CUSHION HANGER - GEL 327



Highest quality construction Aluminum alloy casting. High purity. (B135T6) Heat treated. Supplied in cast aluminum finish Simple 15 degree lateral and vertical adjustment makes installation quicker; easy to set plum to road and Greenlite Traffic design accomodates a wider range of mast arm arc Spring cushioned deflection which reduces mast arm loading Greenlite Traffic's hangers are safer and less prone to repair and replacement. All automatically return to pre-set position All stainless hardware Jam nut/nylock nut locking system 1 per carton Shipping weight: 7 lbs ~ 1 oz

TRI-STUD CONNECTOR ASSEMBLY

This unique design greatly simplifies assembly and disassembly

All stainless hardware

Neoprene gasket for watertight connections to signal housing

Nylock nut locking system

TRI-STUD CONNECTOR ASSEMBLY

- This unique design greatly simplifies assembly and disassembly
- All stainless hardware
- Neoprene gasket for water - tight connections to signal housing
- Nylock nut locking system

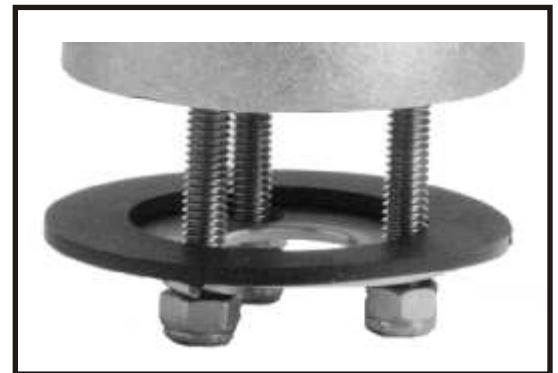

Greenlite Traffic

P.O. Box 64551
Coquitlam, B.C. V3J 7V7
Website: <http://www.GreenliteTraffic.com>

Phone: (604) 936-1961
Fax: (604) 936-1922
Toll Free: 1-888-936-1961
Email: info@GreenliteTraffic.com